

12 11 10 9 8 7 6 5 4 3 2 1

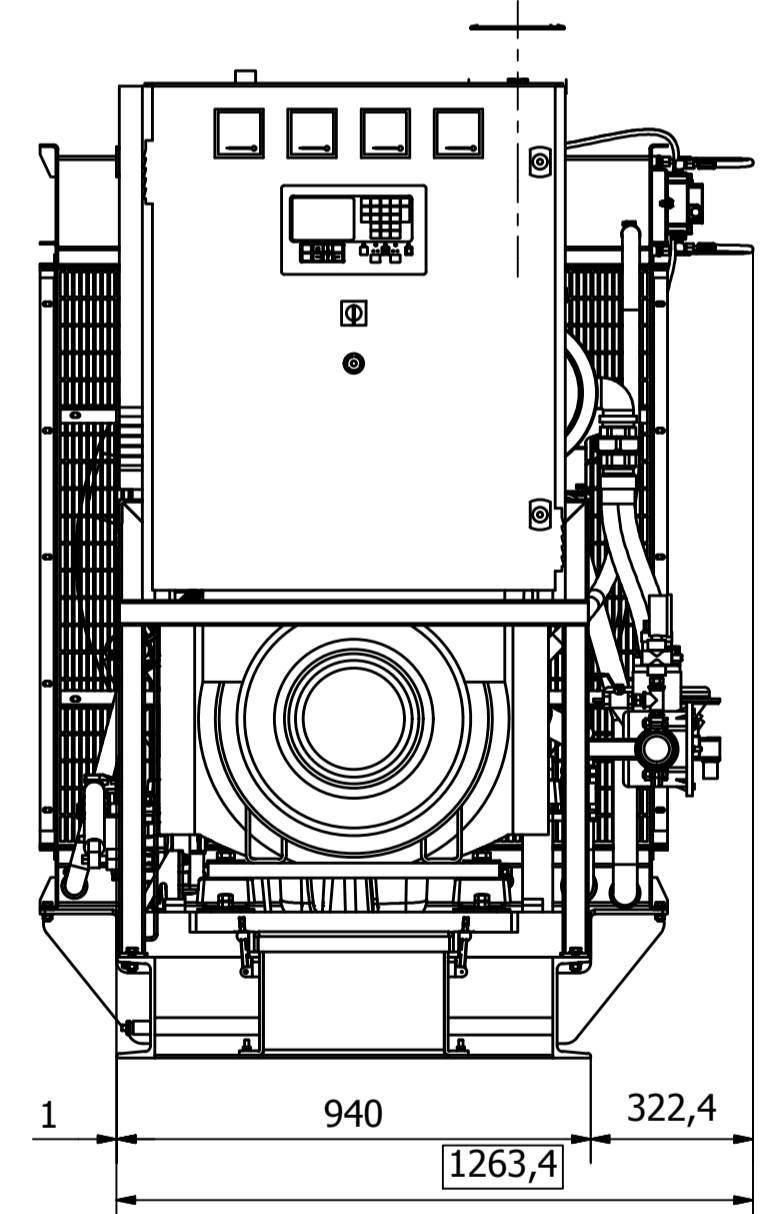
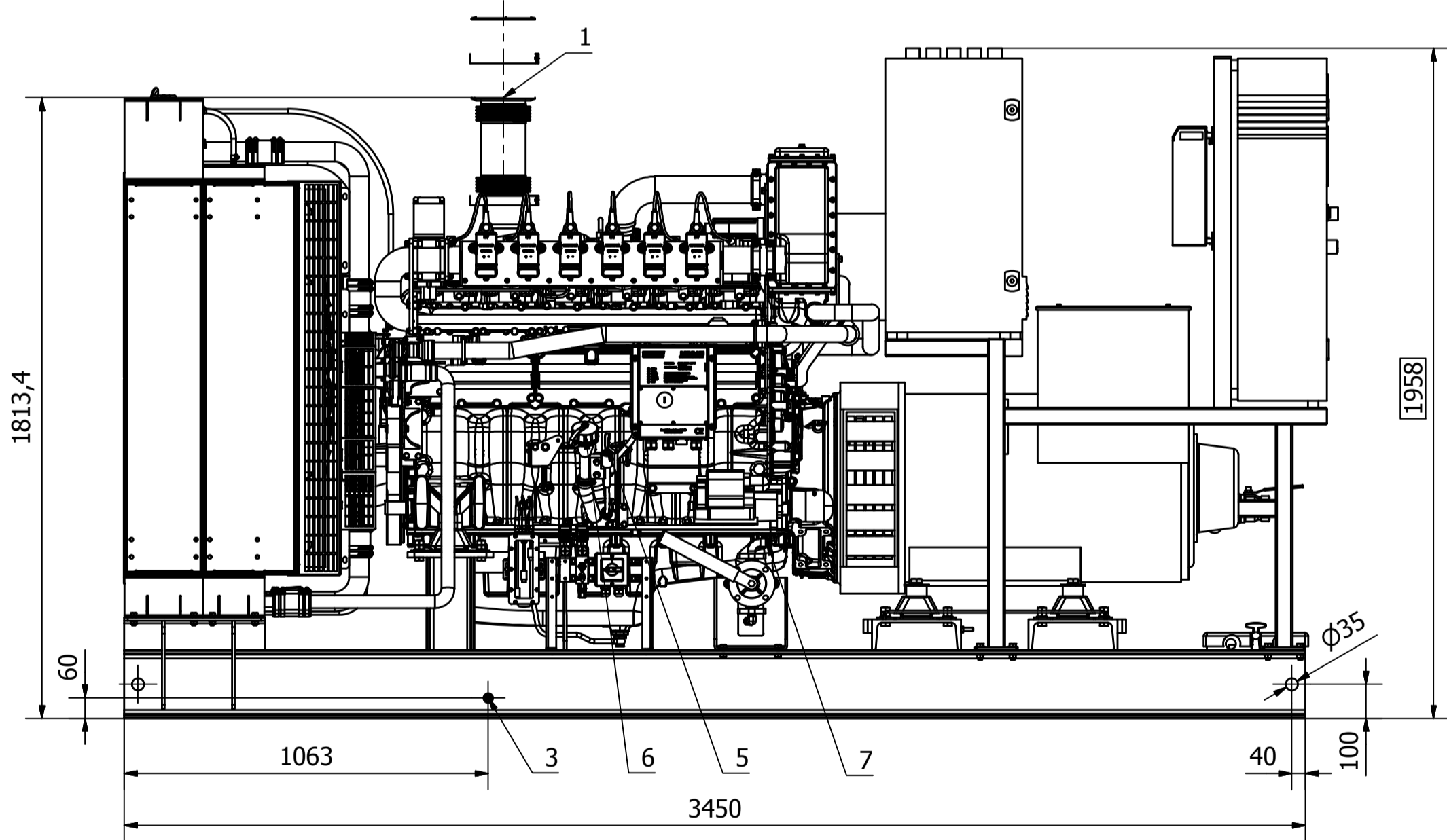
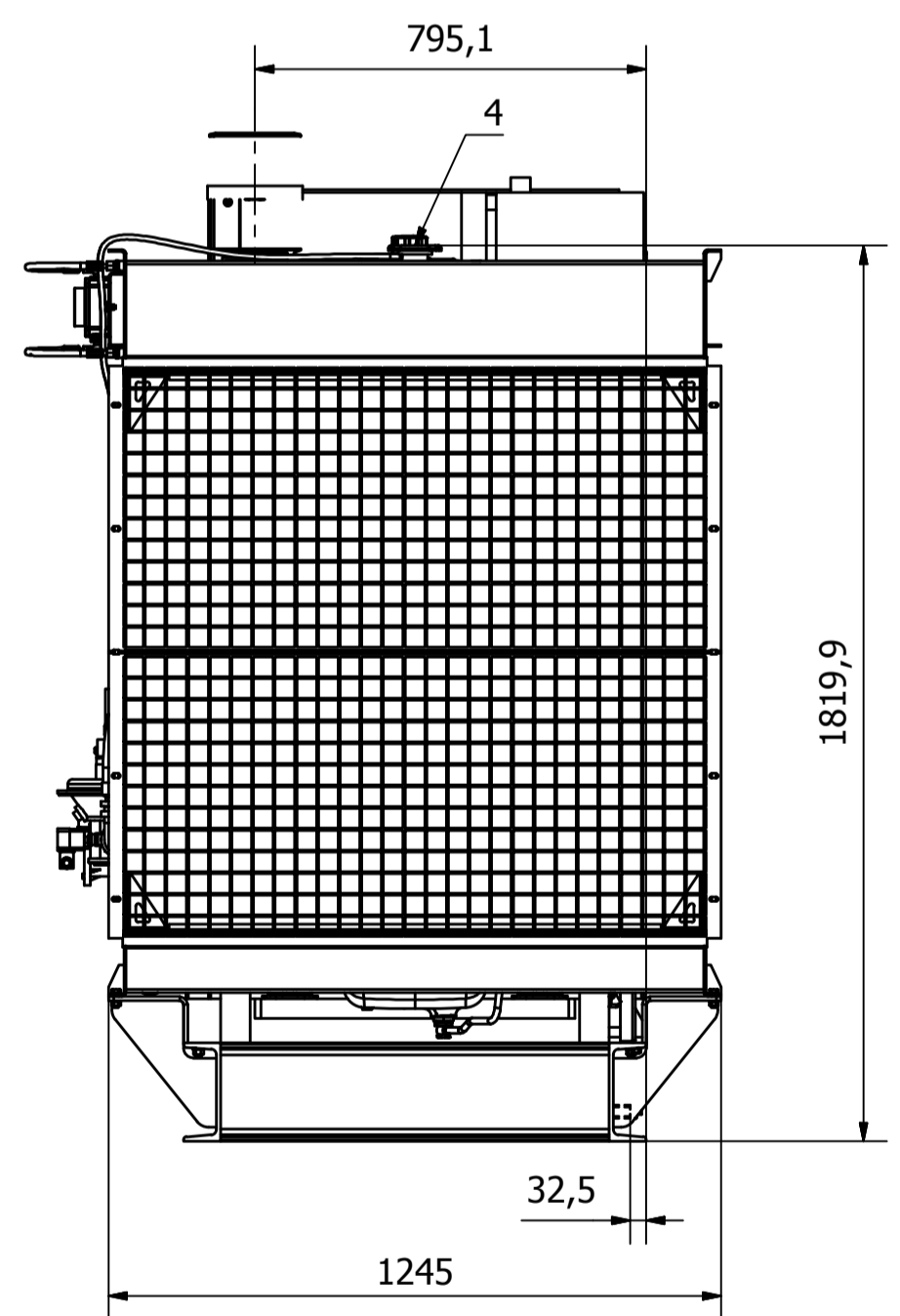
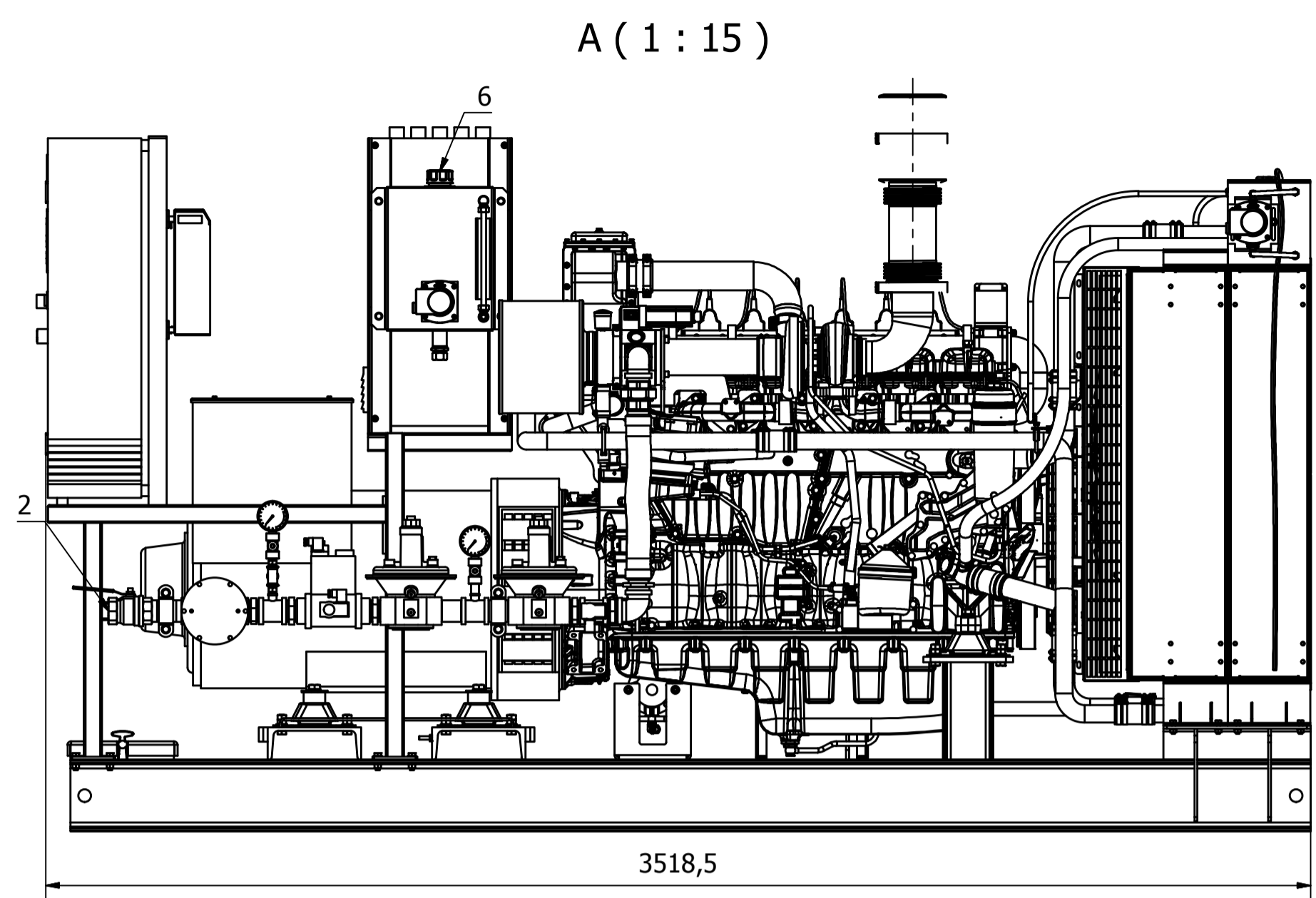
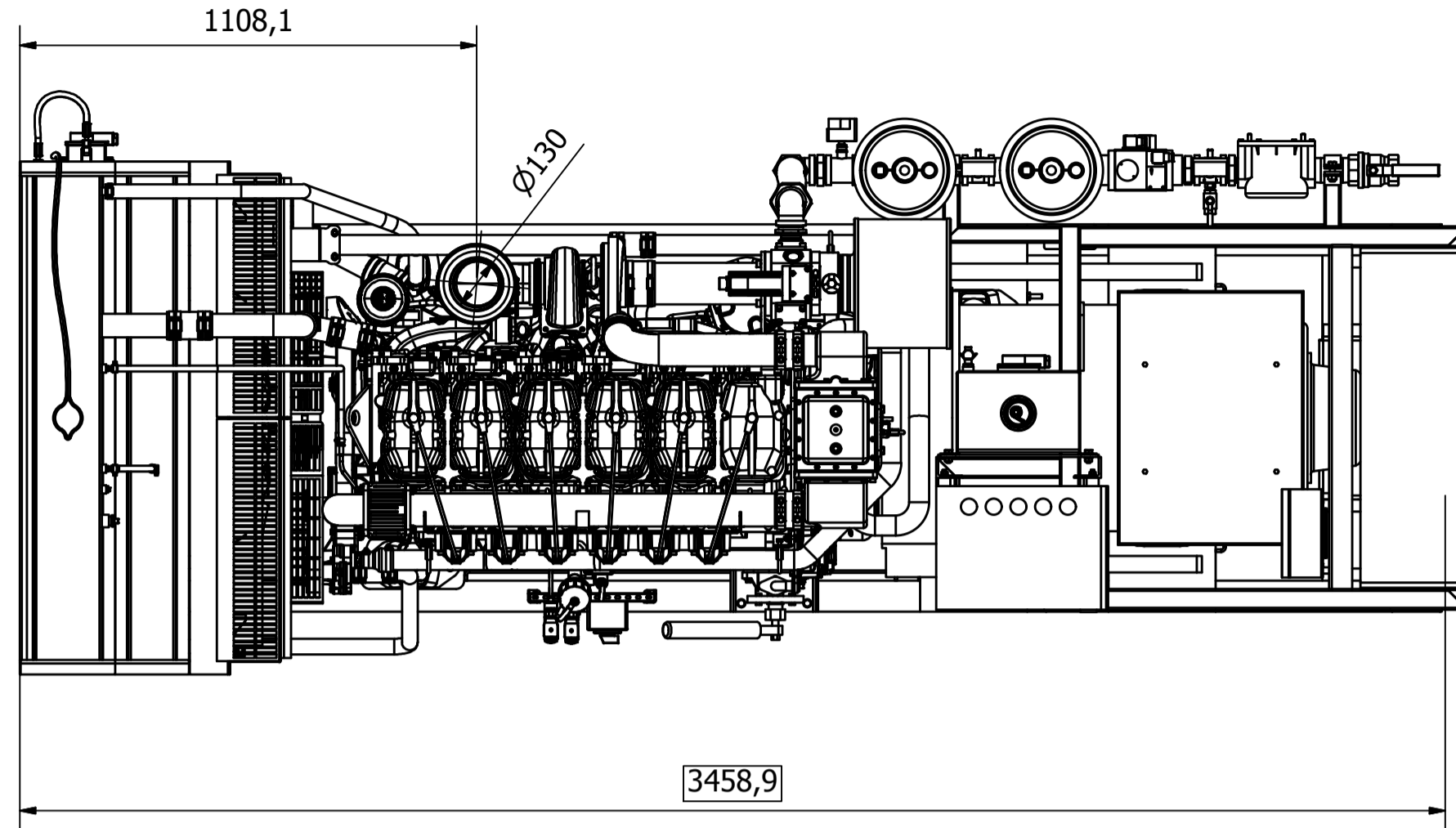
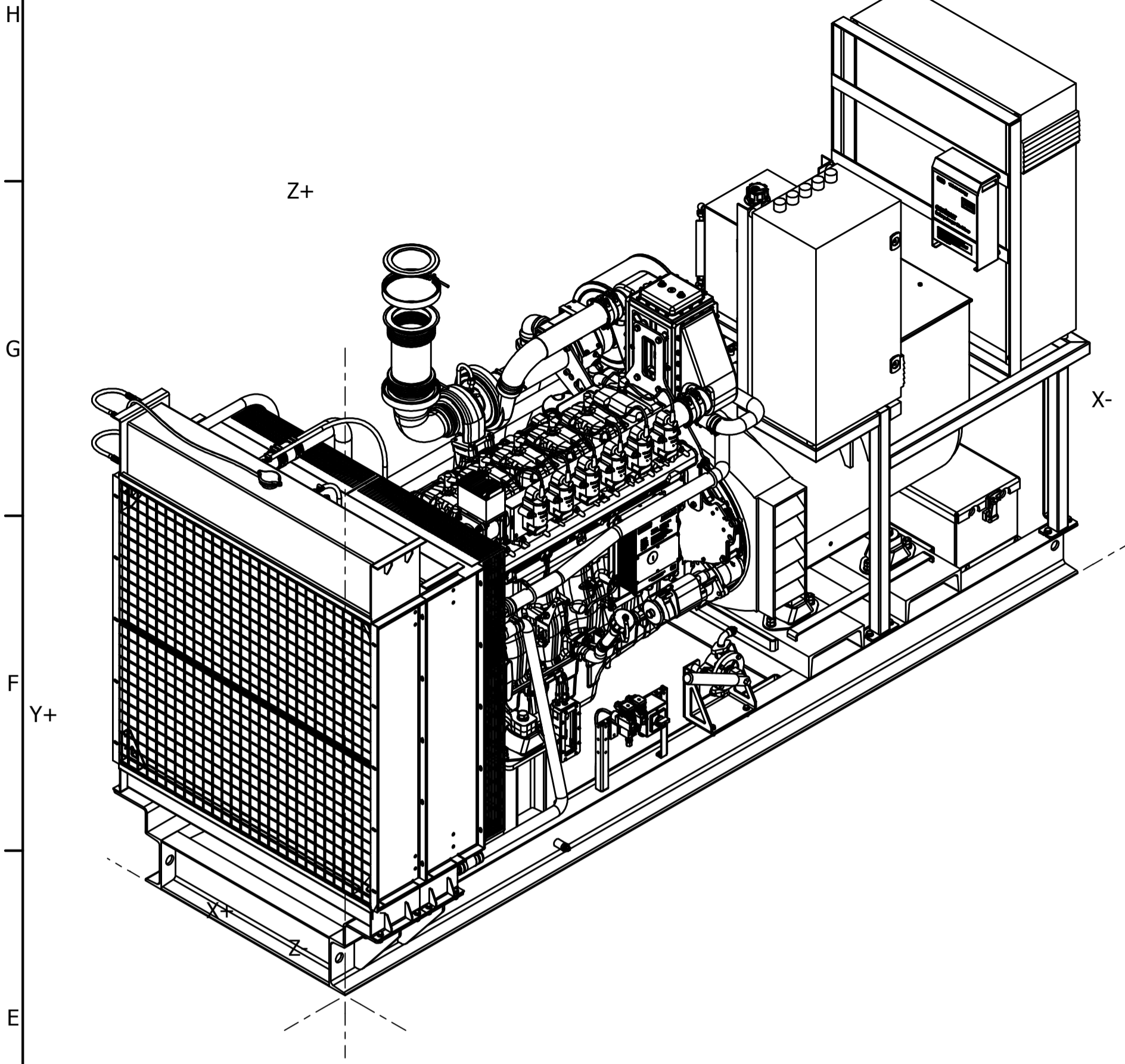

Pos	Discription	Connections			
		Size	X	Y	Z
1	Exhaust	See drawing	-1108,1	795,1	1813,4
2	Fuel in	G 2"	-3382	1011,2	898
3	Drip pan drain	1/2"	-1063	32,5	60
4	Coolant fill	x	x	x	x
5	Oil dipstick	x	x	x	x
6	Oil fill	x	x	x	x
7	Oil drain pump	x	x	x	x

Perliminary
May change without notice
 Electrical cables not drawn.
 Engine piping has to be terminated one meter of the indicated connection
 and made to fit at engine placement.

	General notes: (Unless otherwise noted): Tolerances ISO 1302 class A	Break sharp edges Heat treatment not required Corrosion coating not required	In case of doubt ask for clarification	Material: Weight: N/A Comment: 189 kW gas genset SGI-13 STM - HCl 434 D 237 kVA - 189 kW - 50 Hz	Rev.: C1 Format: A1 Sheet: 1 / 1
	Drawn: Hilco Bodde Checked: Jack Lont Units: mm	Date: 3-10-2014 Date: 30-9-2014 Scale: 1 : 15	Havertoren 1 1779 GS Den Oever The Netherlands Tel.: +31 227513613 Fax.: +31 227513600 URL.: www.sandfirden.nl Copyright © Sandfirden Technics B.V.	140504 GL 621 B - 50 Hz - R	

12 11 10 9 8 7 6 5 4 3 2 1